

- **PMC: PCI bus 32-bit, 33MHz**
- **IPC429 – Next generation 429 core**
- **Improved architecture to enhance performance**
- **16 Transmit and 16 Receive Channels**
- **Programmable High/Low Speed Operation**
- **Upto 256 Label memory for each Receive channel.**
- **128 Word Tx and Rx FIFOs for each Transmit and Receive channel**
- **Programmable interrupts**
- **Asynchronous and Synchronous Messaging**
- **Programmable Refresh rates of 20ms min to 200ms max**
- **Full Error Injection & Detection**
- **Rate-oriented Label Transmission**
- **Rear P14 or Front I/O available**
- **IRIG-B Time Code Input (Digital)**
- **48-bit, microsecond time-tagging**
- **Label Selective Trigger for Capture/Filtering**
- **Optional discrete I/O and IRIG-B**
- **Optional Disconnect of Arinc429 transmit channels through PhotoMos Relays**
- **Driver & High-level API for Windows XP, Windows 7 and Linux**

OVERVIEW

The AT-PMC-429 IP card enables electronic systems to interface with commercial and military avionics data buses. They provide extensive functionality and are used to communicate with, simulate, test, and monitor ARINC429 equipment and systems. This high-density high-performance card is suitable for applications ranging from test equipment to rugged deployable systems. The card is available in front and rear panel I/O, various ARINC channel counts and capabilities.

The card is designed to transmit and receive messages up to 32 channels. Up to 16 channels for Receive (Rx) and 16 channels Transmit (Tx) mode. Each channel is software configurable for high or low speed (12.5k or 100k bits per second) and ARINC429 protocol requirements.

To provide I/O and processing expansion capabilities, IO are available on either rear user IO connectors or Front Panel VHDCI Connectors. An onboard IRIG-B time encoder and decoder allows users to accurately synchronize single or multiple modules to a common time source.

The ARINC data word can be decoded and sorted based on the Label and SDI bits and stored in FIFOs. The card is integrated with a powerful software that reduces development time. All databus functionality is supported from our advanced API (Application Programming Interface). The AT-PMC-429 card is available in Conduction-cooled version.

Software

The AT-PMC-429 IP software includes Drivers and APIs. The card comes with a powerful set of library functions to access the entire ARINC429 functionality. The drivers are designed in a modular fashion consisting of component functions and application functions. The user's test program can be developed with few calls to the driver, by using the set of Application functions provided. Driver and high-level API libraries for Windows XP, Windows 7 and Linux are available.

AT-PMC-429 IP

High Performance Arinc429 Mezzanine Card

PRODUCT SPECIFICATIONS

Bus Interface

- PMC - 32-bit, 33/66 MHz (PCI 2.2)

ARINC429 Interface

- Supports up to 32 ARINC429 channels
- 16 Transmit Channels
- 16 Receive Channels
- 128 Word deep FIFO on each channel
- Programmable Interrupts
- Built-in Fault Detection Circuitry
- Set parity per channel (odd/even/data)
- Sync output on all or selected messages
- Handles periodic and transfer protocols
- Message filters and schedules
- Data Rates: 12.5/50 Kbps in low speed and 100Kbps in high speed
- Standard input levels: ± 6.5 to ± 13 VDC
- Filtering: Label and/ or SDI
- Parity: Odd, even or none
- Error reporting: Parity
- Output levels: ± 10 VDC

Diagnostics

- Testing of Memory Elements
- Testing Transmit/Receive functions
- Internal Loopback and Wraparound Test for each channel
- Interrupt Function Testing

Error Conditions

- Sequence Error
- Address Error
- FIFO Overflow Error
- Receive Data Parity Error
- ARINC Clock Error

ORDERING INFORMATION

Hardware Selection

AT-PMC-429 IP-Controller-Channels-DIO-IRIG-Ruggedization

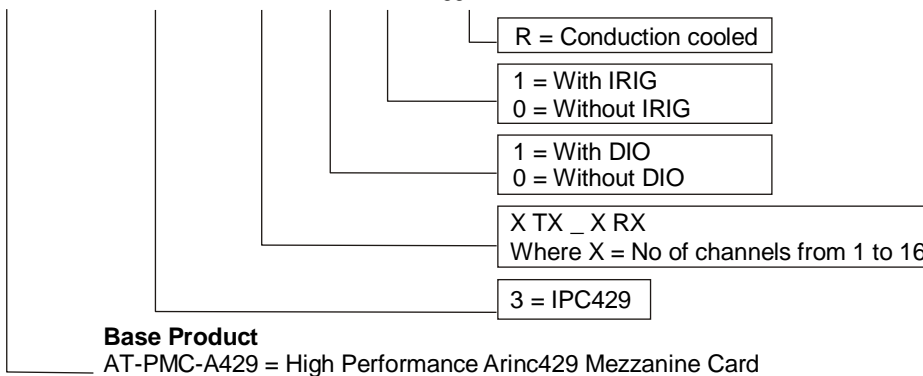

- IO available on both Front Panel 68 pin VHDCI Connector and Rear Connectors
- 48-bit hardware time-tag (1 μ s resolution)
- IRIG-B Time Code Input (Digital)
- Supports Legacy or Standard Modes

Discrete I/O

- Optional Six TTL Discrete Inputs & six Discrete Outputs in PMC mode

IO Configurations

- IO available on both Front Panel 68 pin VHDCI Connector and Rear Connectors (P14)

Software Support

- Driver and high-level API libraries for Windows XP, Windows 7, Linux
- Sample applications provided

Physical

- Standard Single wide Mezzanine Card form factor conforming to IEEE 1386.1 (74 mm x 149 mm)
- Conduction Cooled PMC Card without Bezel

Environmental

	Air-Cooled	Conduction-Cooled
Operating Temperature	0°C to + 60°C	-40°C to + 85°C

Power

- Supply +5V, +3.3V, +12V and -12V from PMC Connectors
- All other voltages are internally derived

Warranty

- 1 year limited warranty

- Contact sales for support for other Operating Systems
- Contact sales for configuration of front and rear I/O configuration
- Contact sales for environmental options



ADTECElectronic Instruments Pvt Ltd
563/1, PRERANA TOWERS, Ranka Colony
Road, Off BG Road, Bengaluru 560076
Email : sales@adtec.in
Website : www.adtec.in

Distributor/Reseller